

ABG 4820

ASPHALT PAVERS TRACKED

EU STAGE IIIA | EPA TIER 3



A small machine with big potential

- Machine's size and weight enables transport with additional equipment
- Auto track tensioner for smooth paving starts*
- Large hopper with front apron (option)
- High fuel efficiency

Control with ease

- EPM3: intuitive control with a bird's eye view of a paver on the display
- Settings Manager to store and save customised settings
- Pave Assist with Thermal Profiling, Weather View and Material Manager
- A very low noise level simplifies communication with the paving team

Highly efficient

- Powertrain components are perfectly harmonised for high efficiency
- Volvo (Deutz) Stage V engine offers unrivalled durability and performance
- Adaptive Eco Mode matches engine output to demand, resulting in up to 30% fuel savings
- Electronically adapted speed of the hydraulic cooling fan lowers noise and fuel consumption
- Grid power for heating the screed with e+ screed heat, no fuel + no CO₂

State-of-the-art service

- Service Interval Manager notifies the operator of required maintenance
- CareTrack advanced telematics system
- Service access from the platform provides ease of maintenance
- MATRIS provides expert analysis of machine operating activity

Industry-leading screeds

- ABG designed screeds heat quickly
- The robust screed design produces a consistent, high-quality mat
- Easy screed control with the clear screed panel design
- Quick-coupling for easy vario screed extension assembly*
- Fully hardened tamper bars significantly extend lifetime

**AN ABG EXCLUSIVE FEATURE*

ABG 4820

EU Stage IIIA | EPA Tier 3

ENGINE	ABG 4820	
MANUFACTURER	Volvo (Deutz)	
MODEL	D4E	
FUEL	Diesel	
OUTPUT	kW	96
	hp	129
AT ENGINE SPEED	r/min	2 200
COOLANT	Liquid	
FUEL TANK CAPACITY	l	180
EXHAUST EMISSION	EU Stage IIIA / EPA Tier 3	

PAVING

OUTPUT (THEORETICAL)*	t/h	500
MAT THICKNESS (MAX)	mm	300

*The actual paving output depends upon the mat thickness, the paving width and paving speed and will vary according to paving conditions prevailing on your jobsite.

SPEED

PAVING (MAX)	m/min	20
TRANSPORT (MAX)	km/h	3.6

UNDERCARRIAGE

LENGTH	mm	2 850
WIDTH (TRACK PLATES)	mm	300

CONVEYOR

HOPPER CAPACITY	t (sh tn)	13.5
NUMBER OF CONVEYORS		2
CONVEYOR SPEED (MAX)	m/min	14

AUGER

SPEED (MAX)	1/min	68
DIAMETER	mm	360

OPERATING WEIGHTS* OF SCREEDS IN KG AT WORKING WIDTH

ABG 4820	5 m	6 m	6.5 m
VB 78 ETC	3 528	-	5 150
VB 79 ETC	3 730	-	-
VB 88 ETC	-	3 820	-

* Including auger extensions, channel plates, end gates.

DIMENSIONS

		ABG 4820
LENGTH WITH VARIO SCREED (WALKWAY UP)	mm	5 997
WIDTH	mm	2 532
HEIGHT	mm	2 917

WEIGHT

TRACTOR UNIT	kg	12 470
--------------	----	--------

All weights are approx. weights without options.
Weight of tractor without screed, with fuel tank half full, with continuous towing arms, 75 kg driver and weather roof included.

MAX. ALLOWABLE GRADEABILITY

TRACTOR UNIT + SCREED	%	25
-----------------------	---	----

Applies to screed VB 78 2.5–5.0 m.
When using extensions the max. allowable gradeability will be reduced.

SOUND LEVEL

L_{PA} Sound Pressure Level at Driver's Ear, acc. to ISO 11201	dB	79 (with VB 78, VB 79, VB 88, VB 89 screeds)
L_{WA} Guaranteed Sound Power Level, acc. to Directive 2000/14/EC	dB	104 (with VB 78, VB 79, VB 88, VB 89 screeds)

VIBRATION

HAND-ARM VIBRATION accord. to ISO 5349:2001	m/s^2	<2.5
WHOLE BODY VIBRATION accord. to ISO 2631:1997	m/s^2	<0.5

ELECTRICAL SYSTEM

BATTERY VOLTAGE	V	24
-----------------	---	----

TRACKED ASPHALT PAVERS

DIMENSIONS [mm] ABG 4820

A	5 997
B	3 785
C	2 850
D	525
E	360
F	748
G	2 019
H	3 091
I	160
J	155
K	141
L	2 548
M	2 495
N	360 ± 60
O	939
P	1 440
Q	1 608
R	2 235
S	311
T	770
U	300
V OPEN	3 191
CLOSED	2 532
W	3 796
X	275
Y	265

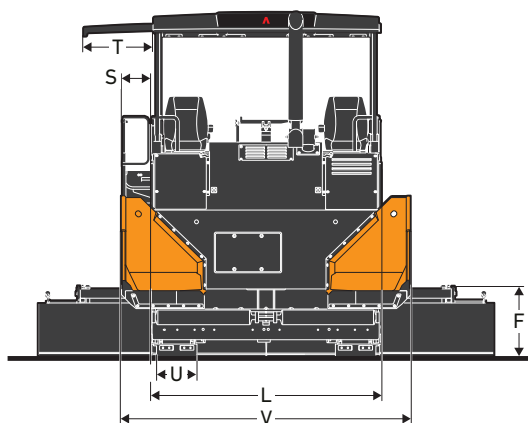
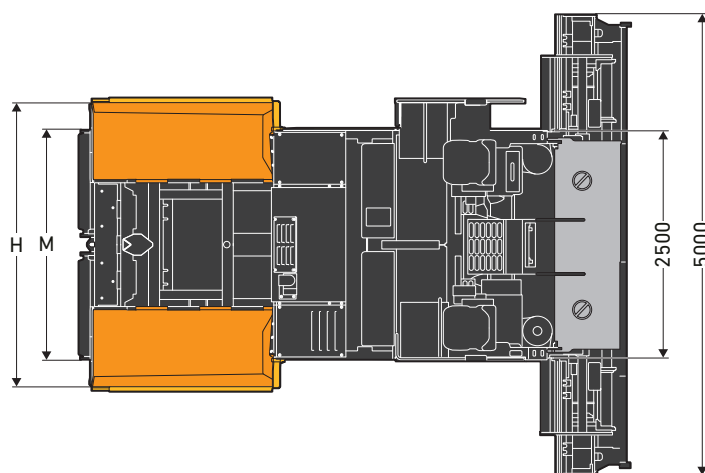
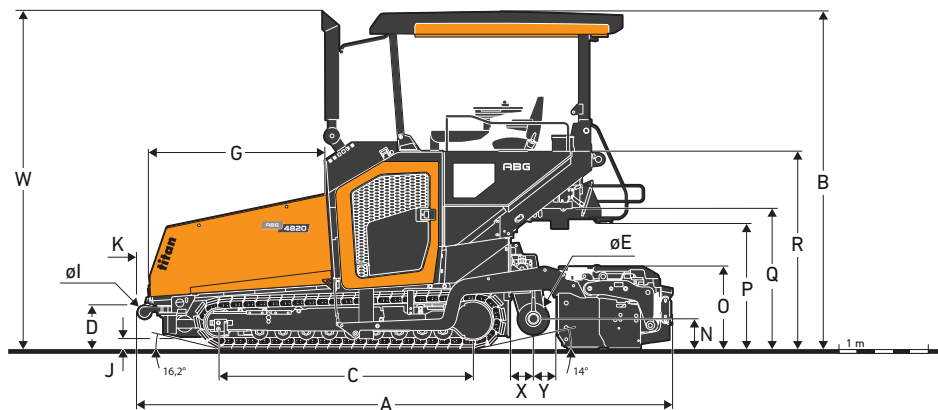

EQUIPMENT

STANDARD EQUIPMENT

Engine

- Volvo (Deutz) Diesel engine, EU Stage IIIA/EPA Tier 3

Drive

- Electronic drive control
- Lifetime lubricated crawler track rollers
- Forged and hardened crawler track links
- Automatic track tensioner
- Bolt on rubber pads

Material management

- Large truck push rollers with 160 mm Ø
- Four individual hydrostatic drives for conveyors and augers
- Reversible direction of auger rotation
- Proportional conveyor sensors

Electronics

- Electronic Paver Management (EPM 3)
- ECO mode

- Settings Manager
- Service Interval Manager
- Adjustable and revolving control panels at operator platform
- Electric switch cabinet
- Battery master switch
- Two adjustable and revolving screed panels
- MATRIS

Structure

- Two seats, laterally extendable
- Anti-vandalism kit
- ABG Key
- Screed
- Hydraulics for Vario screeds with tamper and vibration
- Screed lock

Lights

- Six working lights (LED)
- Operators platform
- Home light function

Environmental

- Sound insulation

OPTIONAL EQUIPMENT

Material management

- Individual operating hopper wings
- Hydraulically operated front apron
- Reversible conveyor
- Hydraulic auger height adjustment
- Proportional Ultrasonic Sensor auger control
- Central lubrication
- Light truck push rollers with 110 mm Ø
- Protective half shells

Electronics

- Levelling systems
- Additional sockets 230V
- Caretrack Advanced
- Pave Assist (Co-Pilot system)
- Smart View camera system
- Smart Dock
- Transport case for EPM control panels

Structure

- Deluxe seats with heating
- Front windscreen
- Tarpaulin side curtains for weather roof

- Custom colour
- Automatic folding device for weather roof (electro-hydraulic)

Screed

- Screed anti-climbing lock
- Screed assist
- Hydraulic height adjustment of extendable screeds
- Hydraulically adjustable Power-Float screed end gates
- Heatable screed end gates

Lights

- 10 working lights (LED)
- Two additional rear lights (LED)
- Auger lighting
- Levelling indicator scale lighting
- Warning beacons

Environmental

- Extractor for bituminous fumes
- Emulsion spraying system
- Heavy-duty spray cleaning gun
- Biodegradeable hydraulic oil